



EV Charging Infrastructure Insights

Presentation at Shaw and Partners

27 March 2023

What we'll share today

- Introduction
- EV Charging market insights
- Process of making a site EV ready
- Customer perspective
- Q&A

We power, automate and connect infrastructure to build a better world

As more countries take action to reduce carbon emissions, demand continues to grow for the products and services essential to deliver responsible economic development.

IPD Group is a vertically integrated provider of end-to-end solutions to the Australian electrical market that help make it possible.



DAVID SULLIVAN |

EV Charging market insights

The road to the electrification of transportation

Not new – an ongoing evolution since the start...



First Production EV

Englishman Thomas Parker – 1 year before Karl Benz created the Gasoline car. The first Porsche was Electric.



EVs Mass Produced

Thousands of EV's in America and the US.



Model T

Electric car vanished – Cheaper Gasoline 16.5M sold.

The road to the electrification of transportation

Not new – an ongoing evolution since the start...



1997

Toyota Prius

First mainstream Hybrid.



2008

Tesla Roadster

First car to run on Lithium batteries
0-100 km/h in 3.7 sec.



2010

Nissan Leaf

Compact car 80 kW synchronous
electric motor 24 kWh Lithium Ion
battery 160km range.

Emerging E-mobility segments



E-Mobility segment focus areas



Residential /Commercial

7.5 – 11kW AC

- Private homes
- Multi-tenant homes
- Residential communities
- Private business



Public Infrastructure

24 – 90kW DC
120 – 350kW DC

- Council on street parking
- Private car parks
- Business parks
- Retail establishments
- Hospitality
- Accommodation



Fleets

7.5-11kW AC
50 – 180kW DC

- Vehicle distributors
- Vehicle service centres
- Vehicle operators / fleets
- Office complex
- Government
- Industrial



Public Transport

50-180kW DC
350-600kW DC

- Depot – overnight
- Enroute - opportunity

Maintenance Repair & Operation

AUSTRALIAN ELECTRIC VEHICLE SNAPSHOT

In 2022, EV sales almost doubled with 3.8% of all new cars purchased being electric.¹

1. [2022 Australian Electric Vehicle Industry Recap - Electric Vehicle Council](#)

AUSTRALIAN ELECTRIC VEHICLE SNAPSHOT

In 2022, Australia had 4,943 public chargers. Of those, only 464 were fast chargers.²

AUSTRALIAN ELECTRIC VEHICLE SNAPSHOT

We require ~20x more public chargers in 2030 compared to today.³

Growth forecast of EV's

Australian Electric Vehicle Council

Estimate that 1 million EV's are needed on the road by 2027 to reach our Net-Zero by 2050 commitments that equates to a **12-fold increase**.

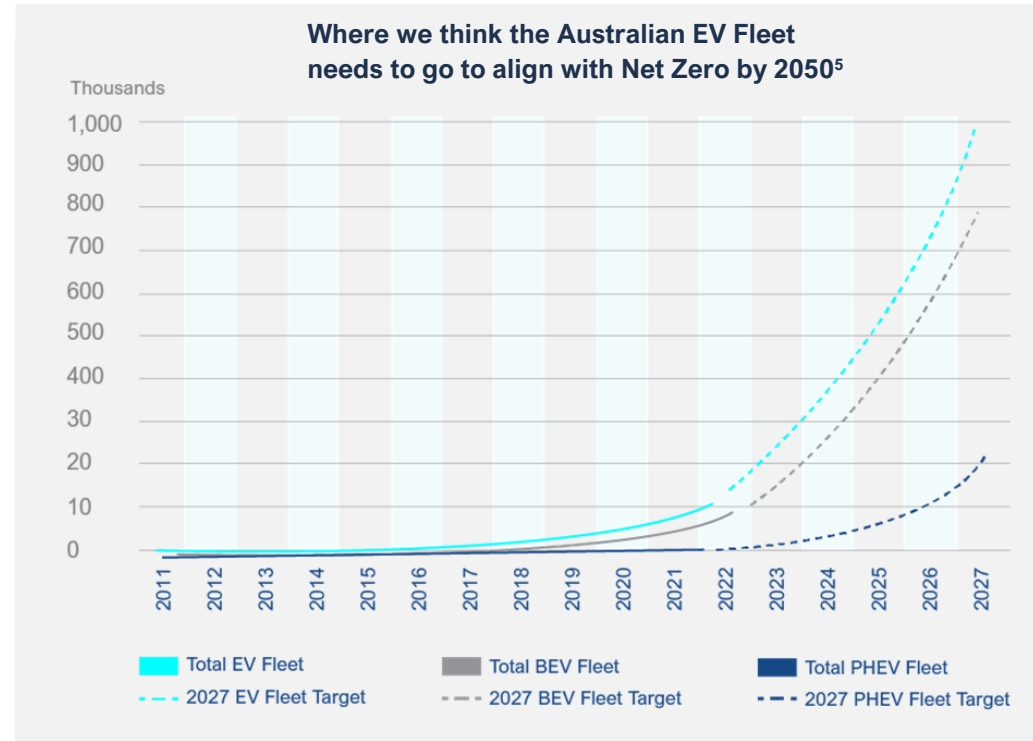
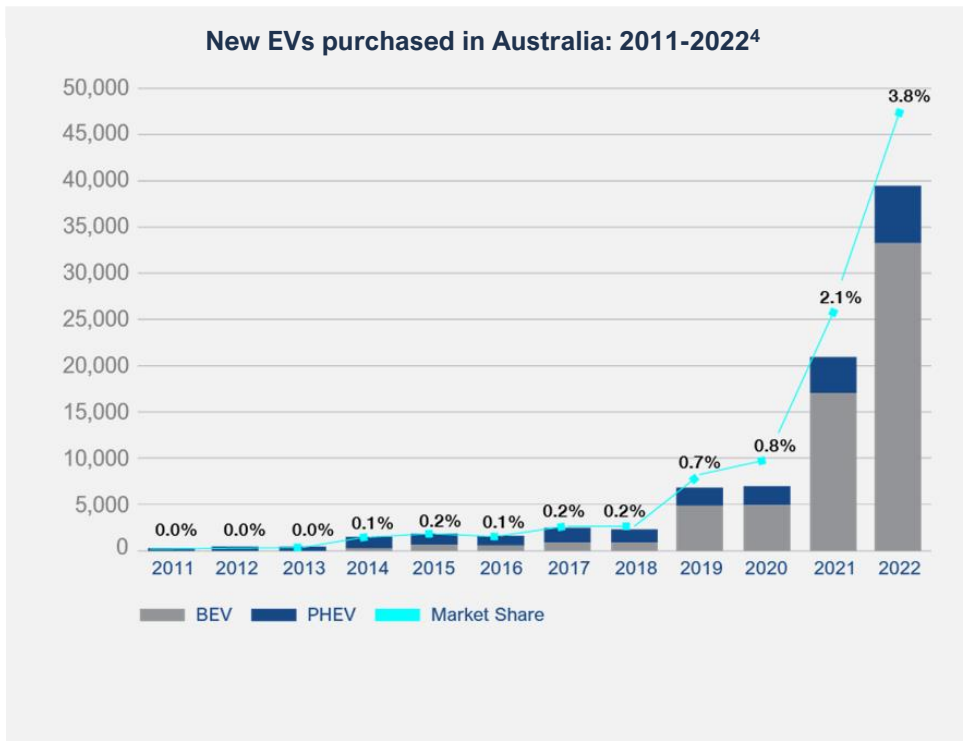

4. EV purchase figures come from a range of sources including VFACTS and direct industry reporting.
 5. Figures do not represent a detailed forecast, but forms the basis of an aspirational target of 1 million light EVs by 2027 in order to get the Australian EV market on track to achieve >50% EV purchases by 2030, and 100% EV fleet by 2050. The split between BEVs and PHEVs is indicative, and reflects a similar 80%/20% BEV/PHEV split reflected in the Australian market over recent years.

‘Step on the pedal’: Australia urged to pick up pace of EV infrastructure

Jenny Wiggins

Australia needs to “step on the pedal” and push ahead with building 2.8 million electric vehicle charging stations by 2030 because there is a shortage of skilled workers to install them, McKinsey & Co consultants say.

Australia could not begin to develop charging infrastructure fast enough because experienced electricians were in short supply globally, McKinsey’s Zurich-based global EV infrastructure leader, Florian Naegele, told *The Australian Financial Review* during a trip to Sydney.

“We’re well advised to step on the pedal in terms of getting ready for rolling out the infrastructure,” he said.

Australia has relatively low numbers of EVs; just over 20,000 were sold last year, representing only 2 per cent of the market for new cars, according to the Electric Vehicle Council.

But McKinsey estimates Australia will have 3 million EVs on the road by 2030, and that the nation will need 2.8 million charging points.

It also forecasts that \$18 billion to \$20 billion of investment will be needed in Australian charging infrastructure over the same period, excluding additional investments that may be needed in the energy grid to provide electricity to EVs.

Sixteen of the biggest global car makers plan to phase out internal combustion engines by 2040, and Mr Naegele said several were expected to beat that target.

“We’re shifting away from the regulatory-induced push [to EVs] and just I think surpassed the pivotal point where it becomes a consumer pull,” he said. He added that the risk of poor demand for charging infrastructure

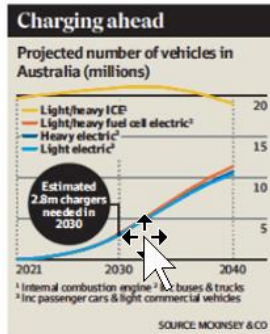

Eventually the transition to electric vehicles does improve the fuel security of Australia.

David Dyer, McKinsey partner

that had previously worried some investors was “eroding rapidly”.

He had no qualms that there will be sufficient investment in charging stations, pointing to a spate of share-market flops by charging companies including the US’s EVgo and Australia’s Tritium, which listed on the Nasdaq exchange, and the Netherlands’ Allego, which listed on the New York Stock Exchange.

But there is uncertainty over who will bear the costs of installing charging stations in existing buildings such as apartment blocks, where some tenants may have EVs but others do not.

Although shortages of semiconductors and strong demand for commodities used to make batteries (such as lithium) had raised the costs of some EVs, over the long term McKinsey expects electric cars will be cheaper to make than petrol-fuelled vehicles.

“From an architectural point of view we have no reason to believe that an EV cannot be more cost-effective than an internal combustion engine,” Mr Naegele said.

Melbourne-based McKinsey partner David Dyer said EVs were becoming more affordable compared with petrol cars as smaller models became available and consumers assessed the rising cost of fuel.

A shift to EVs would boost Australia’s energy security because the nation would no longer have to import so much liquid fuel (which comprises about half of all energy consumed in Australia), Mr Dyer said.

“Eventually, the transition to electric vehicles does improve the fuel security of Australia because we’re no longer dependent on oil imports.”

Electric batteries are also being considered by trucking groups. Volvo, Daimler Truck and the Traton Group (a subsidiary of Volkswagen) said in December they would team up to install and operate a public charging network for long-haul electric trucks and coaches across Europe.

Hydrogen fuel cells are expected to replace diesel fuel in trucks in Australia. Producer Hydrogen Fuels Australia and project developer Clara Energy said yesterday they had agreed to build a green hydrogen refuelling network for trucks along the Hume Highway between Melbourne and Sydney.

Their first hydrogen refuelling station is due to open in 2025.

2.8 million chargers required by 2030

3 million EV’s on the road by 2030

Forecast \$18 – \$20 billion of investment required

16 of the largest global car makers to phase out ICE by 2040

Total solution provider

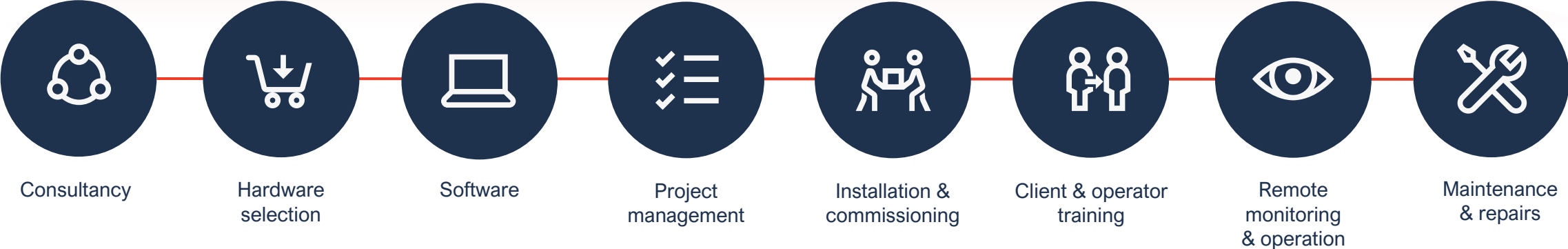

ED KESTEL |

Process of making a site EV ready

Understand the opportunity with EV charging and associated electrical infrastructure.
There is a lot more to EV charging than **just** the charger.



1

▶ EV Charging Infrastructure

● Types of chargers

● Hardware

● Software

● Types of sites

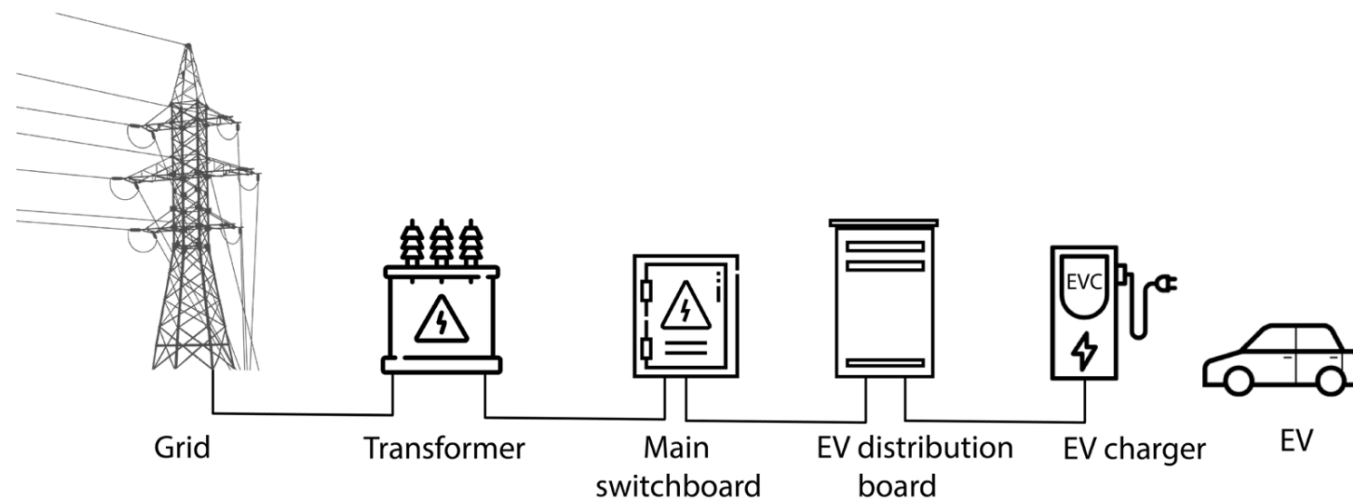

EV Charging Infrastructure

- A typical charging station and how it connects to the grid.

1

- EV Charging Infrastructure
- ▶ Types of chargers
- Hardware
- Software
- Types of sites

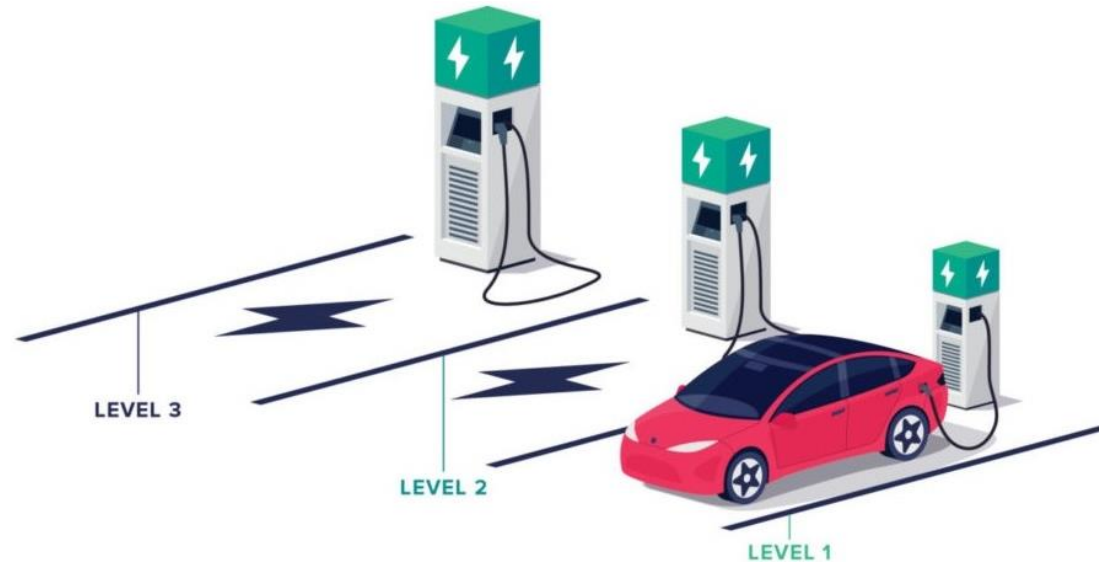

Types of chargers

Level 1 - Portable 10amp/15amp, charging is slow.

Level 2 - AC Chargers home/public/destination chargers 7kW to 22kW, charging is fast.

Level 3 - DC Fast chargers 25kW to 350kW. Perth has 50kW, charging is ultra fast.

*** Limiting factor to the speed of charge is the onboard charger ***

1

- EV Charging Infrastructure
- Types of chargers
- ▶ Hardware
- Software
- Types of sites



Hardware

- Select charging infrastructure based on the site operation needs.
- Understanding driving patterns of the drivers is critical.
- Be agnostic and select the right chargers for the solution.

1

- EV Charging Infrastructure
- Types of chargers
- Hardware
- **Software**
- Types of sites

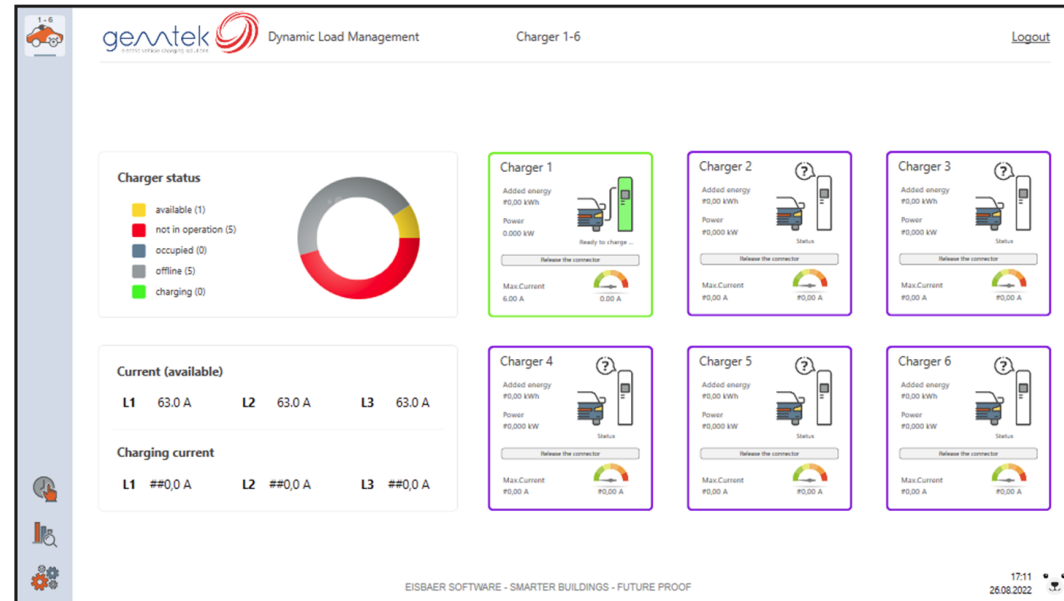

Software

- Energy Management, load shifting to reduce demand from chargers and unnecessary upgrades.
- Charging optimisation, co-optimisation of vehicle duty cycle, fleet uptime and fuel costs.
- Interoperability, open-standards like OCPP will avoid vendor lock-in.
- Home integration, track your fleet vehicles charged at employee homes to allow reimbursement.

1

- EV Charging Infrastructure
- Types of chargers
- Hardware
- Software
- ▶ Types of sites



Types of sites

- Public charging hubs.
- Commercial properties ie. shopping centres, tourist destinations and commercial businesses.
- Multi-residential and strata.

2

▶ Design considerations

- Understand the usage profile
- Understand existing electrical infrastructure & capacity
- Select the EV chargers & produce layout drawings
- Installation
- Configure charging stations



Design considerations

- Smart site selection mitigates project costs and timelines.
- Site assessment, while equipment cost may be known, installation cost can vary wildly. Detailed site assessment helps develop an efficient installation plan.
- Early engineering and design, asking the right questions about the types of usage enable a detailed engineering plan to be developed for future expansion.

2

- Design consideration
- ▶ Understand the usage profile
- Understand existing electrical infrastructure & capacity
- Select the EV chargers & produce layout drawings
- Installation
- Configure charging stations



Understand the usage profile

- The first step is to obtain a time series data set to create a car park usage profile.
- Helps establish the baseline number of cars that are parked at any given time interval and provides insights into the likely change in energy draw from charging EVs at the given site.
- Allow for predicted EV car sales growth.

2

- Design consideration
- Understand the usage profile
- ▶ Understand existing electrical infrastructure & capacity
- Select the EV chargers & produce layout drawings
- Installation
- Configure charging stations



Understand existing electrical infrastructure & capacity

- Key factor is determining how the electrical supply can accommodate the EV demand.
- A site inspection is conducted to assess the capacity of the existing electrical infrastructure.
- Determine the capacity of the local substation, incoming conductors, and main switchboard.
- Several electrical infrastructure upgrades such as distribution boards, cabling and metering are required depending on the specifics of the installation.

2

- Design consideration
- Understand the usage profile
- Understand existing electrical infrastructure & capacity
- ▶ Select the EV chargers & produce layout drawings
- Installation
- Configure charging stations

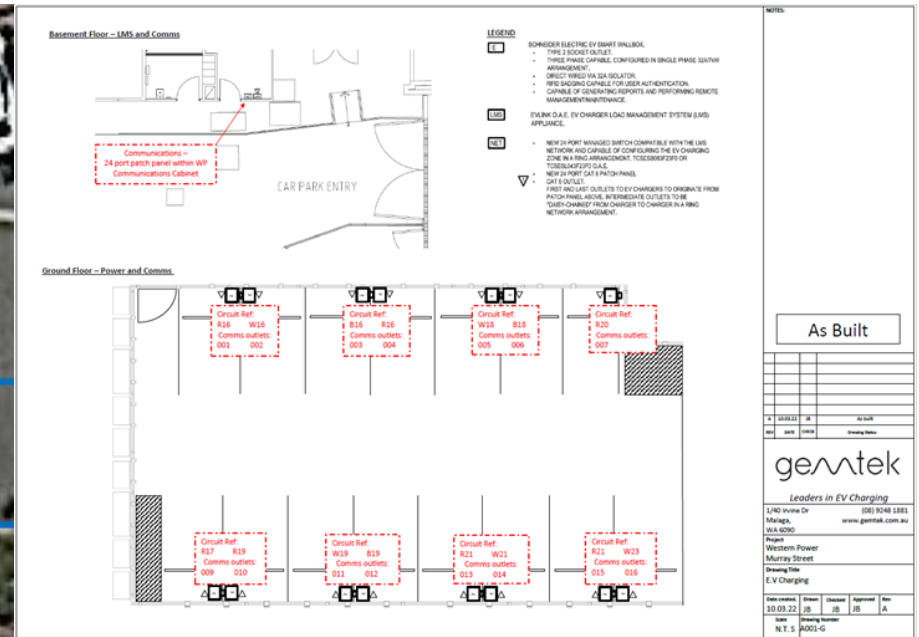
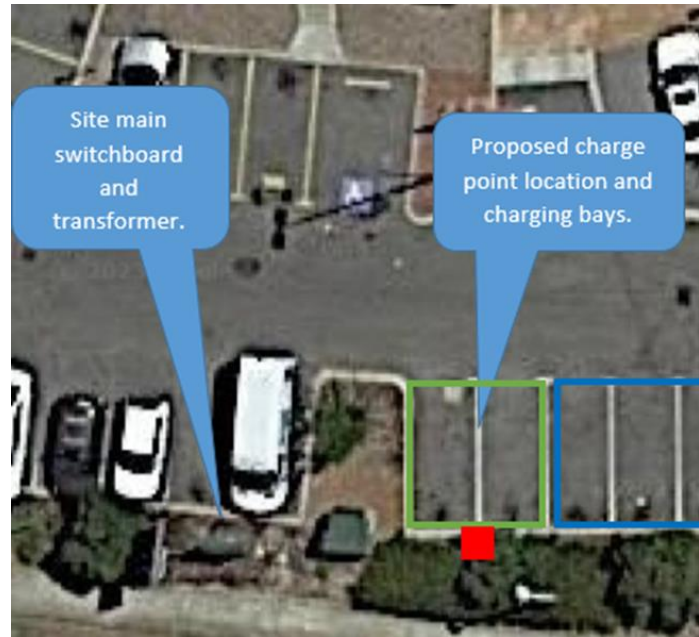

Select the EV chargers & produce layout drawings

- The outcomes of the usage profile and subsequent EV infrastructure model determines the number of charge points.
- A graphical representation of the model and design is created that includes the location of bollards, access, cable paths, and an electrical schematic.

2

- Design consideration
- Understand the usage profile
- Understand existing electrical infrastructure & capacity
- Select the EV chargers & produce layout drawings
- ▶ Installation
- Configure charging stations

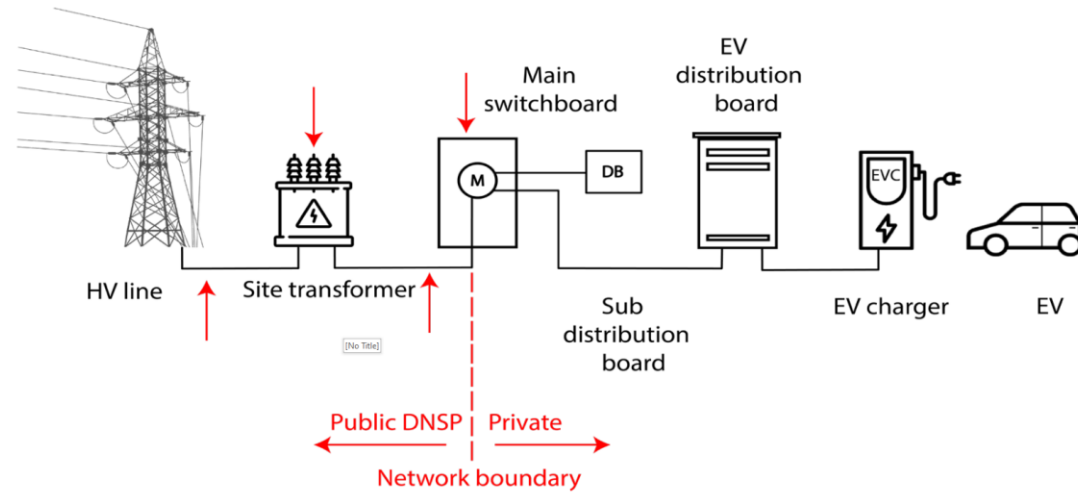

Installation

- Depending on the size of electrical infrastructure upgrades there are two types of electrical contractors that need to be engaged.
- One that holds expertise on electrical activities behind the meter.
- Another that is proficient in conducting in front of the meter.
- We uniquely offer both.

2

- Design consideration
- Understand the usage profile
- Understand existing electrical infrastructure & capacity
- Select the EV chargers & produce layout drawings
- Installation
- ▶ **Configure charging stations**



Configure charging stations

- Begin by optimising the charging system.
- Deciding if the chargers should be managed as a group or individually.
- How the software should enable customer payments and designate pricing rates, e.g., time-of-use or variable rates.

3

▶ Operations, maintenance & repairs



Operations, maintenance & repairs

- Marketplace has suffered in the early years from poor maintenance and service support.
- Significant opportunity of recurring revenue via maintenance, repair and operation contracts.
- Gemtek is well placed to take advantage of this through our national field service teams.



▶ Case study

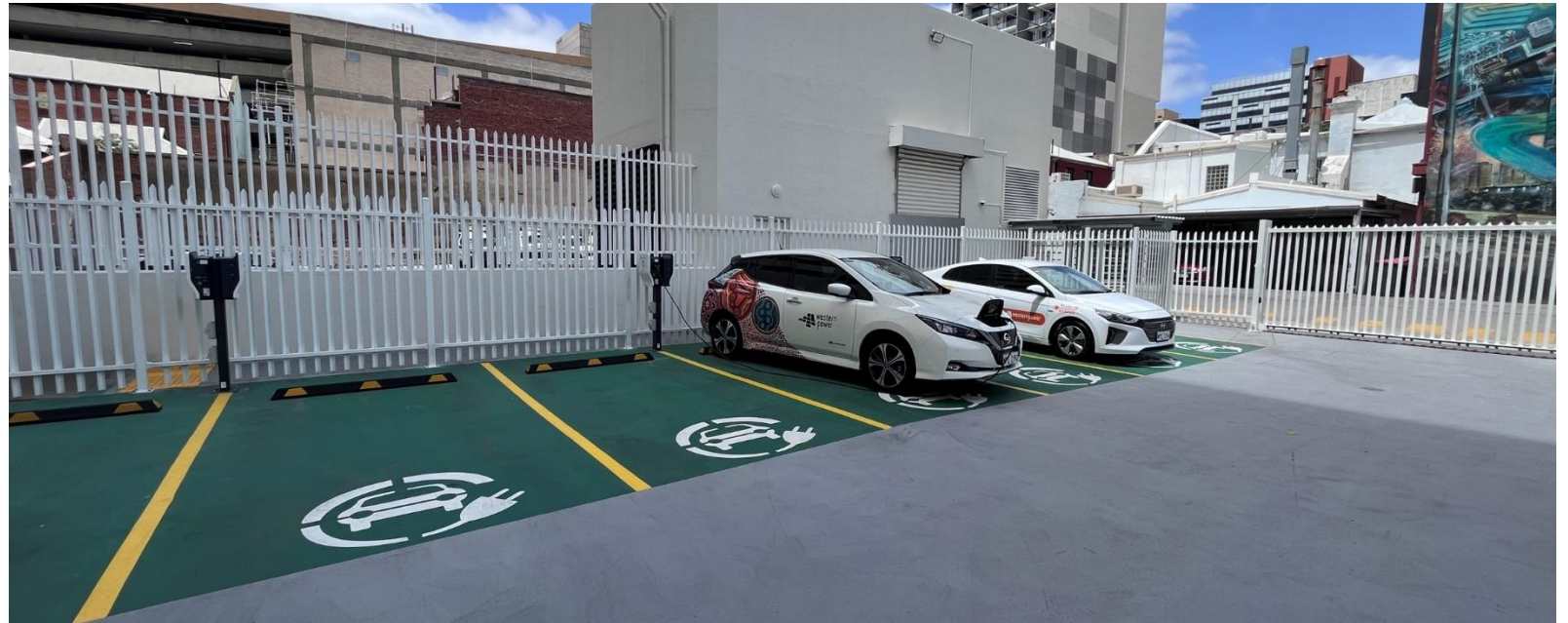

Case study – Western Power

- EV charging to 15 x Mitsubishi Outlanders.
- Limited power available at the car park switchboard.
- Fleet utilization reports.
- Load management required, with new power meters.

CHRIS DODD |

Gemtek customer perspective

- ▶ Who are the Dodd & Dodd Group?
- ▶ What do you use Gemtek for and why?
- ▶ How many sites have you worked with Gemtek on?



Central Island layout



Solar Canopy's

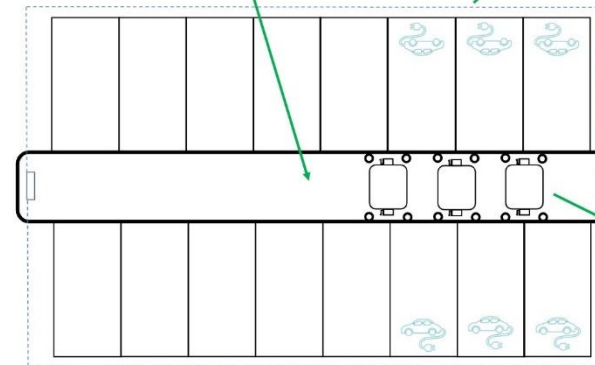

Proposed EV Charging Hardware



EV CHARGING
INFRASTRUCTURE
INSIGHTS |

Q&A

Important notice & disclaimer

NO RELIANCE

The information contained in this document is not investment or financial product advice and is not intended to be relied upon as the basis for an investment decision, and is not, and should not be assumed to be, complete. The information provided in this presentation may not be suitable for your specific needs and should not be relied upon by you in substitution for obtaining independent advice.

To the maximum extent permitted by law, neither the Company nor any other party guarantees or makes any representations or warranties, express or implied, as to, or takes responsibility for, the accuracy or reliability of the information contained in this document or as to any other matter, or takes any responsibility for any loss or damage suffered as a result of any inadequacy, incompleteness or inaccuracy in any statement or information in this document including, without limitation, any financial information, any estimate or projections or any other financial information.

Past performance information provided in this document may not be a reliable indication of future performance. No representation is being made that any investment will or is likely to achieve profits or losses similar to those achieved in the past, or that significant losses will be avoided. Statements contained in this document that are not historical facts are based on current expectations, estimates, projections, opinions, and beliefs of the Company. Such statements involve known and unknown risks, uncertainties and other factors, and undue reliance should not be placed thereon.

FORWARD LOOKING STATEMENTS

This document contains certain forward-looking statements and comments about future events. Forward-looking statements involve known and unknown risks, significant uncertainties, assumptions, contingencies, and other factors, many of which are outside the control of the Company, are subject to change without notice, and may involve significant elements of subjective judgement and assumptions as to future events which may or may not be correct, and which may cause the actual results or performance of the Company to be materially different from any results or performance expressed or implied by such forward-looking statements. Such forward-looking statements speak only as of the date of this document. Forward looking statements should not be relied on as an indication or guarantee of future performance. No representation, warranty or undertaking is made that any projection, forecast, assumption or estimate contained in this document should or will be achieved. The Company disclaims any obligation or undertaking to disseminate any updates or revisions to any forward-looking statements in this document to reflect any change in expectations in relation to any forward looking statements or any change in events, conditions or circumstances on which any such statement is based.

MISCELLANEOUS

No person, especially those who do not have professional experience in matters relating to investments, may rely on the contents of this document. If you are in any doubt as to the matters contained in this document you should seek independent advice and/or consult your stockbroker, bank manager, solicitor, accountant, or other financial adviser.

A number of figures and calculations in this presentation are subject to the effects of rounding. Accordingly, the actual calculation of these figures may differ from the figures set out in this presentation.

All dollar figures within this document represent Australian Dollars unless otherwise specifically stated.

PRESENTATION AUTHORISED BY THE BOARD